



500 LED BLUE

Sharp-edged spot safety light

Protect your staff & assets from hidden threats.

Ensures a visible sharp-edged warning signal on the floor for an increased safety environment.



Premium Lighting Solutions



0861 8797663
TRY SOME

 **TRY SOME**

The 500 LED series work lights are designed to exceed everyday demands in all applications. This specific Blue version of our LED work light range ensures a visible sharp-edged warning signal on the floor for an increased safety environment.

Dimensions

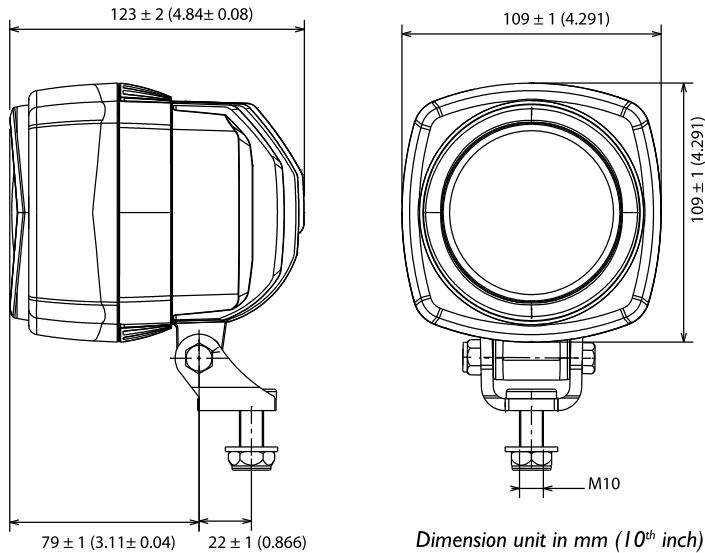

Specifications

Part No.	TBA
Bulb	LED Blue
Lifetime	20,000 hours
Consumption	5W
Voltage	Multi 12-100V
Intensity	0.2 Amp @ 24V
Weight	1.0 Kg
Vibration resistance	10 Grms, from 24Hz to 2000Hz
EMC	ISO 12 895
Load Dump	130V continuous 200V 100 ms 1800V 50 μs
Polarity	no polarity
Water Tightness	IP 68 - IP 69K
Operating Temp	-40°C to +85°C
Salt Spray	ISO 9227
Lens	PC lens
Warranty	20,000 operating hours or 4 years

Application

Any environment where visibility is restricted and heavy machinery operates in close proximity to personnel.



Connections



Built-in
AMP 2 ways

Built-in
DT 2 ways

Mounting Options



Double
Magnetic
Base

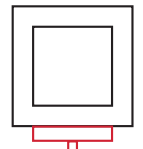

Pedestal

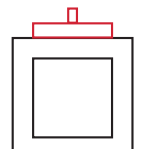

Suspended

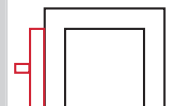

Side Mount

These may not be stock items. Please speak to your sales representative about lead times. Lead times, price and availability can only be determined on receipt of an official quote from our supplier. This can sometimes take up to 3 days.

Gauteng (HO):

T: +27 (0)11 823 5650

North West:

T: +27 (0)14 596 5257

Mpumalanga:

T: +27 (0)13 692 8132

Western Cape:

T: +27 (0)21 945 1453

KwaZulu Natal:

T: +27 (0)31 303 4149

Northern Cape:

T: +27 (0)53 723 3415

Zambia:

T: +26 (0)21 222 5338

Mozambique:

T: +27 (0)72 561 4160

trading@trysome.cc • www.trysome.cc • P.O. Box 13677, Witfield, 1467