

Applications: A pre-lubrication & evacuation system intended for engines of 6 to 10 l displacement or with sump capacities of 7-15 gallons. Systems available for both 12 V and 24 V systems.

Performance: 12 V System (24 V system)

21 °C 15W40 Oil: 4-5 gpm @ 60-70 A (30-40 A) depending on available sump port sizes.

0 °C 15W40 Oil: 2-3 gpm @ 80-90 A (40-50 A) depending on available sump port sizes.

Maximum Duty Cycle (12 V) 6 min ON & 30 min OFF @ <110 A
 (24 V) 5 min ON & 30 min OFF @ <55 A

Ambient Temperature -40 °C to 125 °C (-40 °F to 257 °F)

System Connections:

- Plumbing – Custom fittings are available to connect to the engine. Oil will be drawn through an oil pan port and returned to a port before the existing engine filter.
 - » Suction fitting in sump should have at least 10.16 mm ID (19.05 mm ORB, 12.7 mm NPT, M22) if used w/viscous oil (15W-40 below 4.4 °C). If the available port is smaller, call for alternatives.
 - » Oil filterhead return port should have at least 7.62 mm ID (9.5 mm pipe, 14.3 mm ORB, M16).
 - » Install the pressure switch into the furthest downstream port in the engine's pressurized oil system. Adapters available for most port types and sizes.
- Electrical – Connect the motor to a source of power with the gauge of cables recommended on the next page. Install keyswitch and pressure switch adapter harnesses. Plug the main wiring harness into the connectors at the keyswitch harness, magswitch, pressure switch harness and control relay.

Motor-Pump Components and Features:

- » Motor: Permanent Magnet DC motor. Insulated ground – More reliable than case-grounded motor. High efficiency reduces current draw at all conditions and allows longer motor run time.
- » Pump: Cast-iron housing with steel gears.
- » Integral Relief Valve (175 psi) and seal-protection feature prevent motor or pump damage due to excessive pump pressure.

Components and Features:

- » Timer: Standard Prelub “no delay” relay timer delivers fastest possible start.
- » Wiring: Cable size & fuse prevent wire and motor damage due to excessive current.
- » Motor Switch: Rated for 100 A carry current and consumes minimal power for activation.
- » Inlet Hose: Rated for 148.9 °C oil. Will not collapse under any vacuum level.
- » Pressure Hose: Rated for 148.9 °C oil, and nearly 5 times maximum pump output pressure.
- » Check Valve: Prevents backflow of oil after engine start with minimal restriction and weight.
- » Pump Relief Valve: Standard.

Recommended Hardware:

(Other Plumbing/ Electrical configurations are possible with RPM approval)

Maximum Suction Hose Length (for quick Prelub of typical engine sizes)

Suction Hose ID	Maximum Length
12.7 mm ID	50.8 mm
15.9 mm ID	127 mm
22.2 mm ID	406.4 mm

Maximum Pressure Hose Length (limits pressure or motor current)

**IF Suction Hose Length is > ½ Maximum Length above,
THEN Use Max Permitted Ratio of Pressure Hose Length: Suction Hose Length**

Suction Hose ID	Pressure Hose ID		
	9.5 mm ID	12.7 mm ID	15.9 mm ID
12.7 mm ID	5: 1	9: 1	20: 1
15.9 mm ID	2: 1	4: 1	10: 1
22.2 mm ID	Not Allowed	2.5: 1	6: 1

**IF Suction Hose Length is < ½ Maximum Length above,
THEN Use Max Permitted Pressure Hose Length**

Suction Hose ID	Maximum Length
9.5 mm ID	177.8 mm
12.7 mm ID	254 mm
15.9 mm ID	609.6 mm

Electrical Connections (Total Length = Battery(Power?) Cable + Motor Cable + Ground Cable)

Wire Size	Maximum Length
8 Gauge	762 mm (x4 for 24 V)
6 Gauge	1270 mm (x4 for 24 V)

Maximum resistance of all cabling is: 12 V System – 0.020 Ohm

Motor/Pump Assembly Dimensions:

- Length 10.7" (272 mm)
- Height 3.75" (95 mm)
- Width 4.1" (104 mm)
- Motor/Pump Assembly Weight 11.6 lbs (5.3 kg)

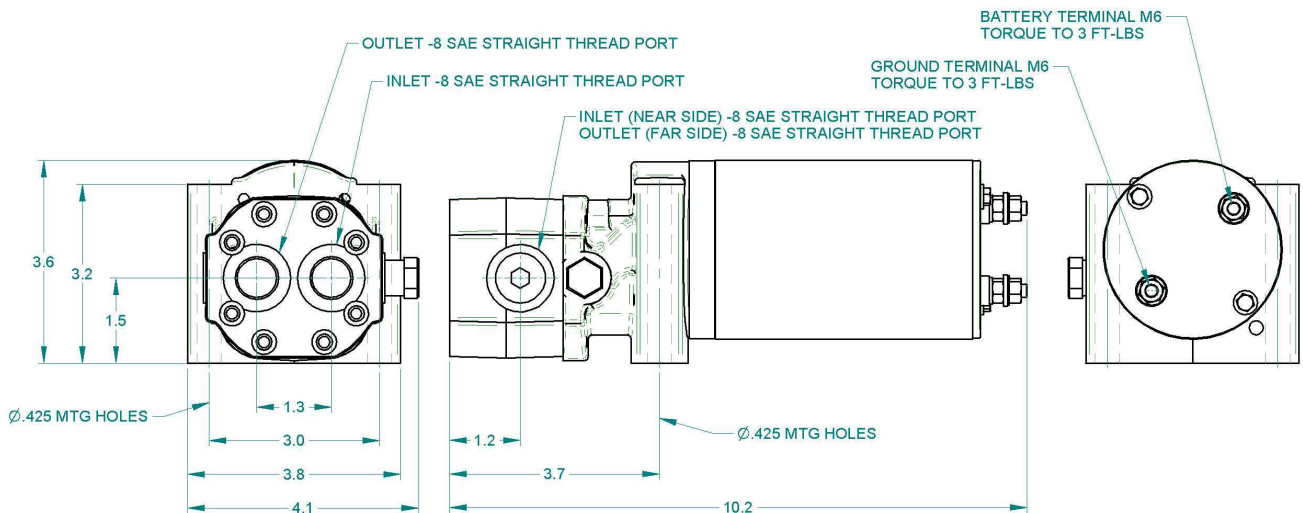

This may not be a stock item. Please speak to your sales representative about lead times. Lead times, price and availability can only be determined on receipt of an official quote from our supplier. This can sometimes take up to 3 days.

- | | | | |
|---|------------------------------|------------------------------|------------------------------|
| South Africa, Gauteng, Jet Park - Head Office: | T: +27 (0)11 823 5650 | | |
| KwaZulu Natal: | T: +27 (0)31 303 4129 | Mpumalanga: | T: +27 (0)13 692 8132 |
| Northern Cape: | T: +27 (0)53 723 3415 | Free State: | T: +27 (0)63 257 0505 |
| North West: | T: +27 (0)14 596 5257 | Botswana, Gaborone: | T: +267 399 4150 |
| | | Botswana, Jwaneng: | T: +267 588 7617 |
| | | Botswana, Letlhakane: | T: +267 297 8568 |
| | | Mozambique, Tete: | T: +258 252 20666 |
| | | Zambia, Kitwe: | T: +26 (0)21 222 5338 |

Call us today!

TRYSOME
AUTO-ELECTRICAL ENGINEERING