

12 V | 2 000 A

GB70
NOCO BOOST[®]HD[™]



START DEAD BATTERIES. ULTRASAFE LITHIUM JUMP STARTER.™

PETROL & DIESEL

UP TO 8.0 L PETROL & 6.0 L DIESEL

Designed for petrol engines up to 8 litres and diesel engines up to 6 litres. For cars, SUVs, trucks, boats, RVs, and more.

USB

CHARGE & RECHARGE

Its internal battery can be used to recharge any personal mobile device like smartphones, tablets, or any other USB device, and it can be recharged by any powered USB port.

40X

UP TO 40 JUMP STARTS

Compact yet powerful lithium jump starter rated at 2 000 amps. Full power to jump start a vehicle up to 40 times on a single charge.

ULTRA SAFE

SPARKPROOF TECHNOLOGY

Safely connect to any 12-volt car battery with our mistake-proof design featuring sparkproof technology and reverse-polarity protection.

NOCO

0861 8797663
TRYSOME



LEAD ACID

WET

GEL

MF

EFB

AGM

AUTO | MARINE | RV | POWERSPORT | LAWN & GARDEN

TRYSOME
AUTO-ELECTRICAL ENGINEERING



INTERFACE

POWER LED

The jump starter is in standby, or the battery voltage is too low for the jump starter to detect.



POWER BUTTON

Push to turn unit "On" & "Off".



CHARGE LED

Indicates the charge level of the internal battery.



BOOST LED

It illuminates white when the boost is active. The LED flashes white when the manual override feature is active.



LIGHT MODE BUTTON

Toggles the ultra-bright LED light through 7 light modes: 100% > 50% > 10% > SOS > Blink > Strobe > Off



ERROR

Illuminates red if reverse polarity is detected. Blinks "On" and "Off" in various sequences to convey error conditions.



MANUAL OVERRIDE

Press and hold the manual override button for 3 seconds, until the Boost LED starts flashing, to enter manual mode.



WHAT'S IN THE BOX

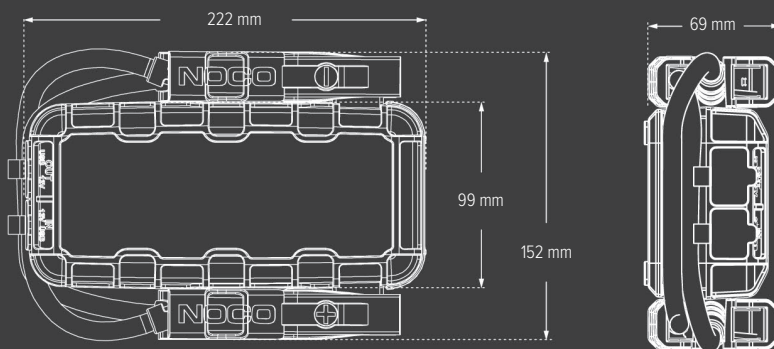

*Accessories not to scale with GB70



XGC Extension Cable



1m USB-MicroUSB

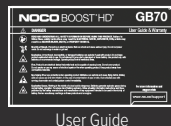

User Guide



XGC 12V Male Adapter



XGC 12V Female Adapter



Microfibre Storage Bag

CHARGE DEVICES

Recharge your personal devices on the go, like smartphones, tablets, e-watches, and more - up to 6 smartphone recharges.

RECHARGE TIME

0.5 A	12 hr
1 A	6 hr
2 A	3 hr

TECHNICAL SPECIFICATIONS

INTERNAL BATTERY:	56 watt-hour Lithium Ion
PEAK CURRENT RATING:	2 000 A
OPERATING TEMPERATURE:	-20 °C TO +50 °C
CHARGING TEMPERATURE:	0 °C TO +40 °C
MICRO USB (INPUT):	5 V, 2.1 A
USB (OUTPUT):	5 V, 2.1 A
XGC (INPUT):	12 Vdc, 3 A Fast Charge
XGC (OUTPUT):	12 Vdc, 15 A Power Supply
HOUSING PROTECTION:	IP65 (with ports closed)
COOLING:	Natural Convection
UNIT WEIGHT:	1.81 kg
UNIT WEIGHT WITH CLAMPS & ACCESSORIES:	2.26 kg
LED FLASHLIGHT:	400 Lumens



This product may not be a stock item. Please speak to our sales representative about lead times. Lead times, price, and availability can only be determined on receipt of an official quote from our supplier. This can sometimes take up to 3 days.

Gauteng - Jet Park (HQ):

T: +27 (0)11 823 5650

Free State - Bloemfontein:

T: +27 (0)63 257 0505

Eastern Cape - Port Elizabeth:

T: +27 (0)82 450 6596

KwaZulu Natal - Pinetown:

T: +27 (0)31 303 4129

Mpumalanga - Middelburg:

T: +27 (0)13 692 8132

Northern Cape - Kathu:

T: +27 (0)53 723 3415

North West - Rustenburg:

T: +27 (0)14 596 5257

Western Cape - Cape Town:

T: +27 (0)21 945 1453

Botswana, Gaborone:

T: +267 399 4150

Botswana, Lethakane:

T: +267 297 8568

Mozambique, Tete:

T: +258 252 20666

Zambia, Kitwe:

T: +26 (0)21 222 5338



SCAN HERE to subscribe and receive our latest product news.

Follow us...



Delivering Optimal **Uptime!**

trading@trysome.co.za • www.trysome.co.za • PO Box 13677, Witfield 1467