

NOCO[®]
Since 1914

GB40 12 V 1000 A 6.0 L | 3.0 L
Lithium Gas Diesel



Auto | Marine | RV | Powersport | Lawn & Garden

NOCO BOOST[®]PLUS[™] JUMP STARTER



START DEAD BATTERIES[™].

CARS, BOATS, MOTORCYCLES, ATVS, TRUCKS & MORE.

UltraSafe, ultra-compact, rugged, and portable lithium-ion Jump Starter. Features spark-proof technology and reverse polarity protection. Instantly jump starts most single-battery applications, up to 20 times on a single charge. Ideal for a wide range of vehicles including trucks and engines up to 6.0 l Gas and 3.0 l Diesel.



SPARK PROOF.

Safely connect to any 12-volt car battery with our mistake-proof design featuring spark-proof technology and reverse polarity protection.

JUMP START. 20X

Full power to jump start a vehicle up to 20 times in one charge. Compatible with engines up to 6.0 l gas and 3.0 l diesel.

USB CHARGE & RECHARGE.

It's internal battery can be used to recharge any personal mobile devices like smartphones, tablets, or any other USB device, and can be recharged by any powered USB port.

100 LUMENS. 2XLED

The GB40 portable car battery jump starter integrates with a high-output 100 lumen LED flashlight with 7 light modes: low, medium, high, flashing, strobe, and emergency SOS.

MORE POWER, A FRACTION OF THE SIZE.

8X

**Lighter &
Smaller**

Compact, portable, pocket-sized jump starter that fits perfectly in your glove box.

1 Year+

**Holds Charge
4x Longer**

The GB40 holds the charge four times longer to extend battery power life and eliminate charge time.

Compared to Leading Traditional Lead-Acid Jump Starters



Error LED. Illuminates Red if reverse polarity is detected.



Manual Override is a special feature designed for rare situations when a vehicle's battery is below 2 volts. Simply press and hold the manual override button for 3 seconds, until the Boost LED starts flashing, to enter into the mode. Press the button again (or the power button) to exit Manual Override. This mode should be used cautiously, as Manual Override disables safety protection while enabled.



TECHNICAL SPECIFICATIONS

Internal Battery:	24 Watt-Hour Lithium Ion	Housing Protection:	P65 (w/ Ports closed)
Peak Current Rating:	1000 A	Cooling:	Natural Convection
Operating Temperature:	-4° F to +122° F (-20° C to +50° C)	Dimensions (LxWxH):	6.7 x 3.2 x 1.7 in
Charging Temperature:	32° F to +104° F (0° C to +40° C)	Unit Weight:	1.65 lbs
Storage Temperature:	-4° F to +122° F (-20° C to +50° C)	Unit Weight w/Clamps & Accessories:	2.4 lbs
Micro USB (Input):	5 V, 2.1 A	LED Flashlight Brightness:	100 Lumens
USB (Output):	5 V, 2.1 A		

Recharging a GB40

(for reference, results may vary)

USB Charger Rating	Charging Time
.5 A	12 hr
1 A	6 hr
2 A	3 hr

WHAT'S IN THE BOX

- GB40 Lithium Jump Starter
- Heavy-Duty Battery Clamps
- 12 V Car Charger
- Micro USB Cable
- Microfibre Storage Bag
- User Guide & Warranty Information

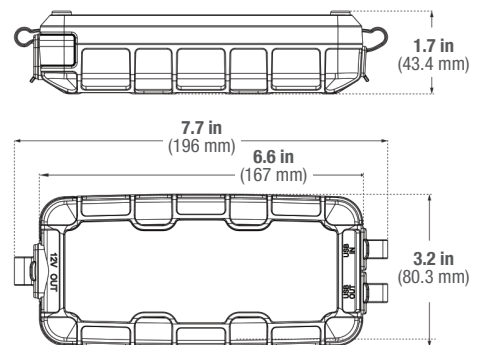
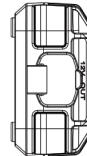

This may not be a stock item. Please speak to our sales representative about lead times. Lead times, price and availability can only be determined on receipt of an official quote from our supplier. This can sometimes take up to 3 days.

Gauteng (HO):

T: +27 (0)11 823 5650

North West:

T: +27 (0)14 596 5257

Eastern Cape:

T: +27 (0)81 036 9111

Botswana, Letlhakane:

T: +267 297 8568

KwaZulu Natal:

T: +27 (0)31 303 4129

Mpumalanga:

T: +27 (0)13 692 8132

Free State:

T: +27 (0)63 257 0505

Mozambique:

T: +258 252 20666

Northern Cape:

T: +27 (0)53 723 3415

Western Cape:

T: +27 (0)21 945 1453

Botswana, Jwaneng:

T: +267 588 7617

Zambia:

T: +26 (0)21 222 5338