

For EXTREME Debris Field Applications



OPTIMAX® is more effective at removing mixed and extreme debris than any other precleaner in the world.

Are you protecting the most vital part of YOUR investment?

Your engine deserves a precleaner that will protect and defend it from all of the enemies in the air.

**Air Flow Range:** Models available for engine air flows from 350 to 1,400 CFM (2.83 to 39.64m<sup>3</sup>/m) and much higher with multiple-unit installations, contact Trysome for details.

**Mounting:** Vertical, requires exhaust scavenging connection

**Precleaner Maintenance:** Stage one, the Series 9000® Precleaner, is self-cleaning and maintenance-free. The cover is removable and is easily accessible for inspection and cleaning (if necessary)

**Applications:** Waste, Mining, Agriculture, Forestry, and more. When you need more than the Series 9000® Precleaner, the OPTIMAX® removes mixed AND extreme debris.

**Recommended Operating Range:** Sea level to 10,000 feet.



D10R with very high CFM requirements has a quadruple OPTIMAX installation

**Coal Mine Maintenance Manager:**

*"The machine runs in the coal load out area. We were replacing filters every 60 hours before we installed the OPTIMAX. Now, we are changing the filter every 500 hours. We have equipped our entire dozer fleet with OPTIMAX systems. That's over 100 machines."*

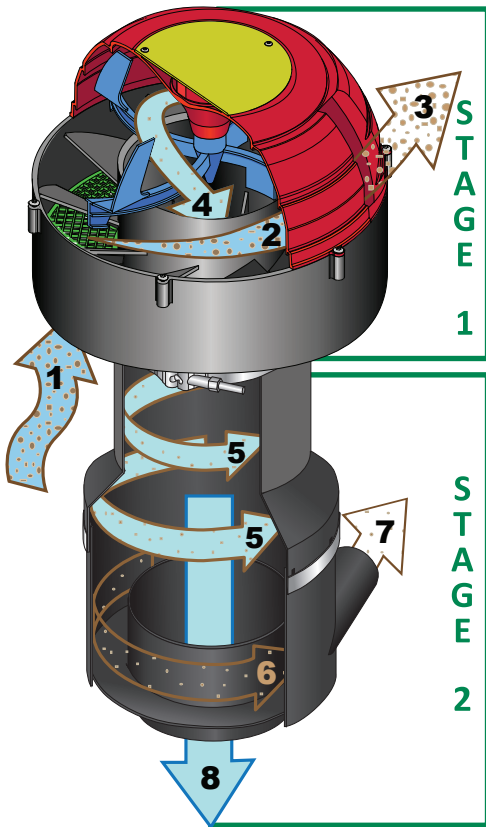

**How it works...**

**Step 1:**

Air enters the OPTIMAX® through a prescreen (or optional heavy-debris screen) that removes the largest contaminants.

**Step 2:**

Curved particle-acclerator blades direct air and dirt up against the side wall.

**Step 3:**

Strakes (angled fins) along the interior surface move heavier-than-air debris towards the ejection slot.

**Step 4:**

The pre-cleaned air exits stage one and enters the second stage of the OPTIMAX®.

**Step 5:**

Remaining debris swirls around the outer walls.

**Step 6:**

Debris is then isolated in the exit tray of stage two.

**Step 7:**

Isolated debris is removed through the machine's exhaust system.

**Step 8:**

Clean air continues to the engine's air filter housing. OPTIMAX® removes mixed AND extreme debris.

**Features & Benefits**

**Extends maintenance intervals**

Lowers cost per operating hour

**Proven to handle extreme conditions:**

Works in all weather

**Minimal maintenance required:**

Reduces maintenance downtime

**Designed with built-in prescreen:**

Blocks large items from intake

**Non-reflective finish:**

Minimal operator distraction

**Dual-stage design:**

Effective in extreme mixed debris conditions



**South Carolina Operations Supervisor:**

*"We really like the OPTIMAX. We've gone from blowing the filters every second day and changing the filters once a week, to changing the engine filters every 300 hours, without ever opening the air filter housing to blow out the filters. The operators are really sold on the systems, and so am I."*

These may not be stock items. Please speak to our sales representative about lead times. Lead times, price and availability can only be determined on receipt of an official quote from our supplier. This can sometimes take up to 3 days.

**Gauteng (HO):**

T: +27 (0)11 823 5650

**North West:**

T: +27 (0)14 596 5257

**Zambia:**

T: +26 (0)21 222 5338

**Authorised Distributors:**

**KwaZulu Natal:**

T: +27 (0)31 303 4129

**Mpumalanga:**

T: +27 (0)13 692 8132

**Mozambique:**

T: +258 252 20666

**Namibia:**

T: +264 64 200566

**Northern Cape:**

T: +27 (0)53 723 3415

**Western Cape:**

T: +27 (0)21 945 1453

trading@trysome.co • www.trysome.co.za • P.O. Box 13677, Witfield, 1467

