



Universal Mount Forward Horn FH312

LONG LIFE • USED BY MAJOR OEMS • CONTINUOUS • LIGHT WEIGHT

The FH312 solid-state, electronic, universal forward horn is the light weight, long life solution specifically designed for the material-handling industry.

The FH312 is used by major OEM's and is recognised by U.L. (a global independent safety science company with more than a century of expertise in innovating safety solutions) for electric vehicles and forklifts. This FH312 can replace high-maintenance, electro-mechanical horns and meets or exceeds all applicable SAE specifications.

Suitable for industrial applications, electric vehicles and fork lifts.

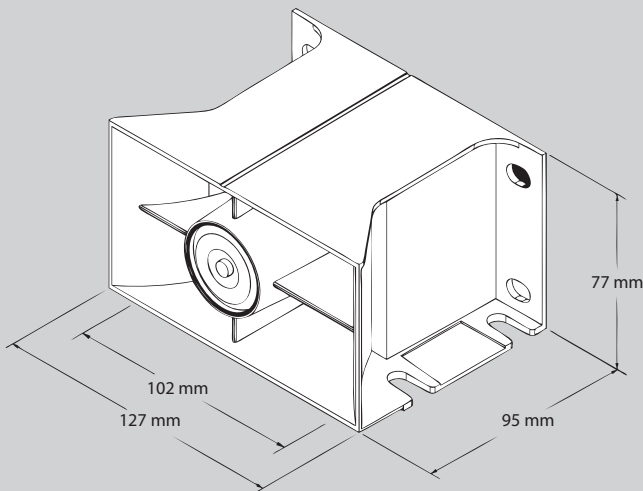
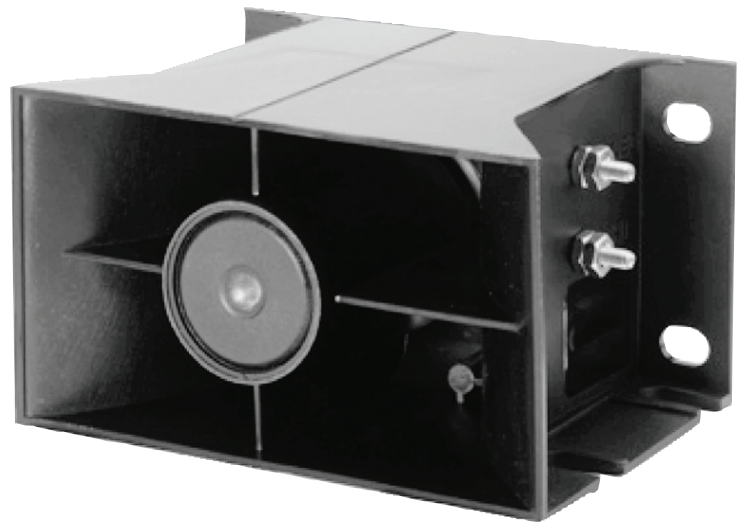

Specifications

Part no.	T175214801
Model no.	FH312
Decibels	112
Sound Level	Continuous
Voltage	12-48 Vdc
Connection	Blade
Max Current	0.3
Approvals	CE, R10, U.L
Weight	681g (1lb .8oz.)
Temperature Range	-40°C ~ 85°C

24-Month Warranty!

This may not be a stock item. Please speak to our sales representative about lead times. Lead times, price and availability can only be determined on receipt of an official quote from our supplier. This can sometimes take up to 3 days.

Gauteng (HO):

T: +27 (0)11 823 5650

KwaZulu Natal:

T: +27 (0)31 303 4129

Northern Cape:

T: +27 (0)53 723 3415

North West:

T: +27 (0)14 596 5257

Mpumalanga:

T: +27 (0)13 692 8132

Western Cape:

T: +27 (0)21 945 1453

Zambia:

T: +26 (0)21 222 5338

Mozambique:

T: +258 252 20666

**Authorised
Distributors:**

Namibia:

T: +264 64 200566

trading@trysome.cc • www.trysome.co.za • P.O. Box 13677, Witfield, 1467

TRYSOME
WE KEEP THE EARTH MOVING!