



**ELECTRO  
MECANICA  
CORMAR**

**NEW**

# Unipolar Battery Master Switch

**24Vdc / 250A**



**T050417501**

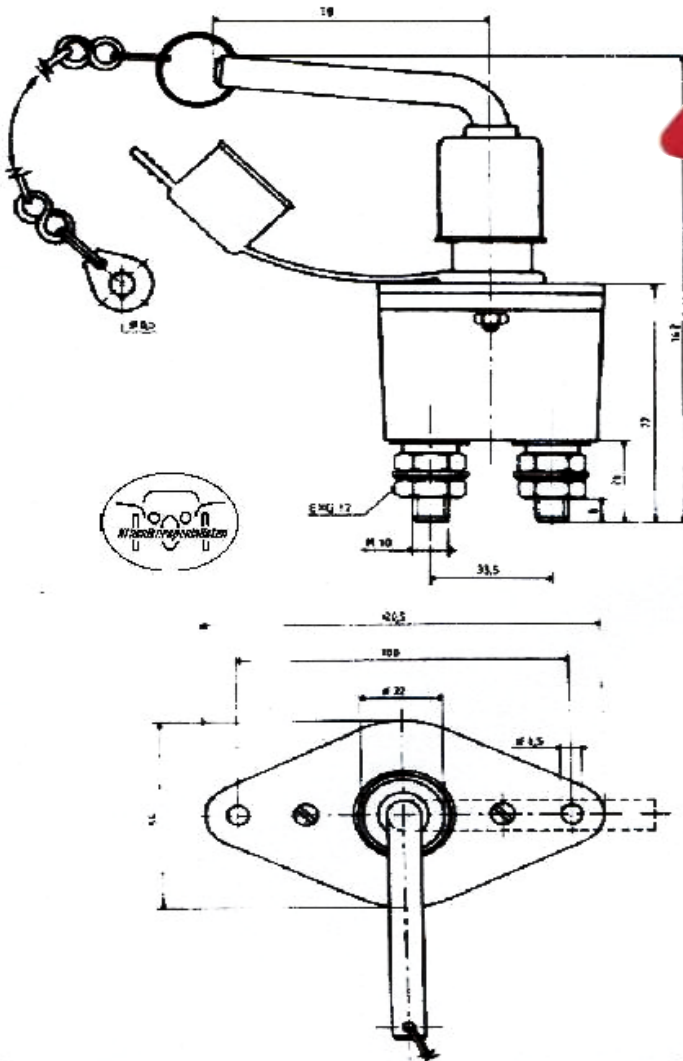

### General Characteristics

- Protection Degree: IP67
- Ambient Temp: -40°C ~ +85°C
- Weight: ± 0.562 Kg
- Contacts: Copper
- Connections: Not polarised

### Particular Characteristics

- Removable handle with PVC protector

### Applications

- Handling vehicles, industrial vehicles, agricultural machinery, industry

### Power Circuit

- Connection: M10 terminals
- Tightening torque: 1.5 ± 0.1 daN·m
- Type: **C1** normally open
- Nominal Current: 250A
- Nominal Voltage: 24Vdc
- Max. capacity: 2500A during 5 sec.

### Spare Parts

- Handle, chain and protection
- Handle
- Strap and PVC protection

**TRYSOME**



**0861 8797663**  
**TRYSOME**

**Johannesburg:** T: +27 (0)11 823 5650 **Rustenburg:** T: +27 (0)14 596 5257 **Witbank:** T: +27 (0)13 692 8132 **Cape Town:** T: +27 (0)21 945 1453 **Durban:** T: +27 (0)31 914 2120 **Kathu:** T: +27 (0)82 383 8335  
**F:** +27 (0)11 823 5662 **F:** +27 (0)14 596 5854 **F:** +27 (0)13 692 8281 **F:** +27 (0)21 949 6188 **F:** +27 (0)31 914 0152

trading@trysome.cc • www.trysome.cc • Box 13677, Witfield, 1467