

Our most advanced Cab Air Quality System in one compact, customisable unit!

The RESPA-CF2 is the most advanced Cab Air Quality System available, delivering a powered precleaner, filter, and pressurizer in one compact, customisable unit.

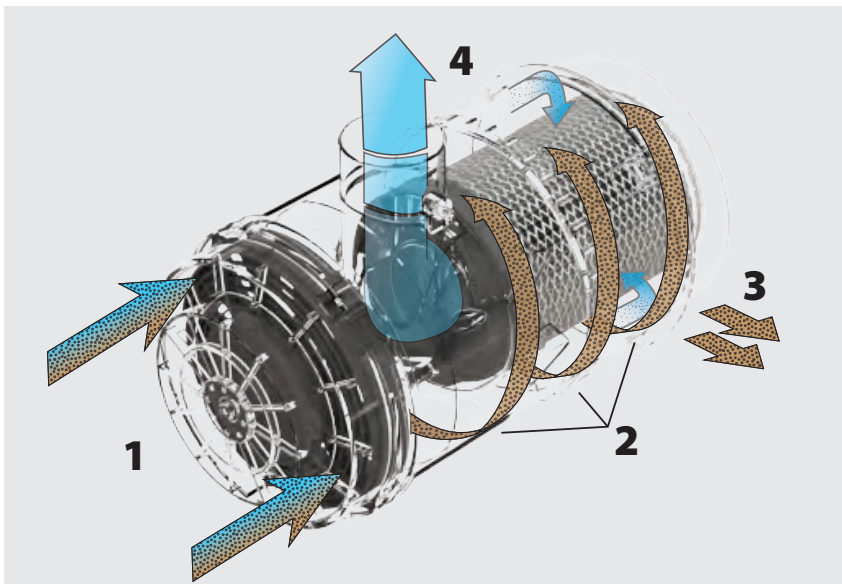

This cab filtration innovation from Sy-Klone International offers the highest quality of filtration and pressurisation at the lowest cost. The cost-effective system extends the HVAC system maintenance intervals while dramatically extending filter life, which saves on filter and labour costs for the user. The powered precleaning technology allows cabs and enclosures to sustain positive pressurisation, helping to keep particulate out. It is the most effective system available today.



How it Works:

1. Air enters the filter housing, laden with particulate debris.
2. Debris-laden air is flung to outside walls in a vortex pattern.
3. Debris-laden air is ejected through the debris ejection ports.
4. After thorough filtration, only clean air enters the air intake housing.

Benefits

- Helps meet regulatory compliance, such as the OSHA Silica Rule and Beryllium Rule
- Extends the HVAC system maintenance intervals
- Dramatically extends filter life up to 20x
- Prefilters air, which helps protect operators from hazardous chemicals and debris.
- Allows cabs and enclosures to sustain positive pressurisation, helping to keep particulate out.
- All-weather, durable, compact, and customisable unit



The RESPA-CF2 offers two sizes to maximise your precleaning ability.

Standard Length Filter Housing

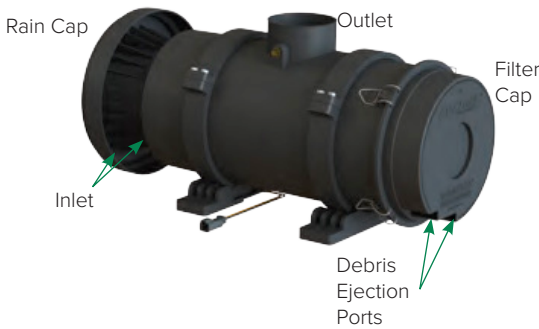

Extended Length Filter Housing

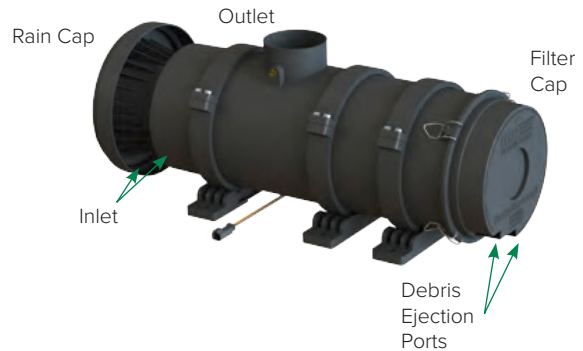

CF-2 Specs at a Glance

- Operating Range: Ideal operation range: 0 CFM to 130 CFM (0 m³/min to 3.68 m³/min) Extended operation range: up to 250 CFM (7.08 m³/min)
- Operation Temperature:
 - Brushless: -40 °C to + 80 °C continuous; +100 °C short exposure
 - Brushed Compact: -20 °C to + 80 °C continuous; +100 °C short exposure
- Construction: glass-filled injection-moulded polypropylene exterior

Mounting Options:

Mounting: horizontal, vertical (rain cap end up)

Precleaner Maintenance:

No routine maintenance is required. The patented self-cleaning filter drops dirt continuously, which is then ejected from the filter housing.

Debris Types:

It expels all types of mixed debris, including mud, snow, rain, leaves, sawdust, chaff, and dust.

Precleaning Efficiency:

It ejects particulate at 90% first-pass efficiency.

Partial List of Industries

Agriculture • Waste – Landfill, Transfer Station, Recycling Facilities, Lift Stations • Mining - All mining (except where an explosion-proof motor is required) • Construction • Demolition • Nuclear Decommissioning • Radioactive Clean-up • Stevedoring • Military • Cell Phone Towers • Power Generation • Utilities • Trucking • Law Enforcement • Forestry • Fire Fighting

Partial List of Applications

All enclosed operator cabs in all environments:

- Heavy equipment cabs
- Stationary equipment cabs
- Cranes
- Drills
- Pipe-laying machines

Power Generation and Distribution:

- Ventilated electric boxes
- Electronic cabinets
- Electronic control rooms
- Computer server cabinets

Environmentally controlled spaces:

- Electronic control rooms
- Portable field offices
- Military portable command posts
- Crusher cabins
- Clean rooms for engine rebuilding
- Dyno rooms
- Cell tower control rooms
- Crew quarters in mining applications



RESPA-CF2 Brushless Motor Systems

Part Number	Voltage	Filter			Outer Diameter		Optional Filtration	
		Type	Part Number	Length	101.6 mm	76.2 mm	Odour/Hepa	Gas/Hepa
RCF2009	12	MERV 16/F9 ¹	FEFF108	STANDARD	•		•	
RCF2010	24							
RCF2025	12	HEPA/H13 ²	FEFF118					
RCF2026	24							
RCF2011	12	MERV 16/F9 ¹	FEFF109	EXTENDED	•		•	•
RCF2012	24							
RCF2027	12	HEPA/H13 ²	FEFF119					
RCF2028	24							
RCF2013	12	MERV 16/F9 ¹	FEFF108	STANDARD		•	•	
RCF2014	24							
RCF2029	12	HEPA/H13 ²	FEFF118					
RCF2030	24							
RCF2015	12	MERV 16/F9 ¹	FEFF109	EXTENDED		•	•	•
RCF2016	24							
RCF2031	12	HEPA/H13 ²	FEFF119					
RCF2032	24							

¹Media Rated at MERV 16, F9 under EN779. ²Rated H13 under EN1822-1.

Compact versus Brushless Motors



Brushed Compact Motor Specifications



Brushless Motor Specifications

- **12 V Amperage***: Startup: 16 A; Running: 6.5 A
- **24 V Amperage***: Startup: 8 A ; Running: 3.0 A
- **Operating Temperatures**: -20 °C to 80 °C
- **Motor Life****: 12 000-15 000 hours
- **Warranty**: 2 Years

- **12 V Amperage***: Startup: 20 A; Running: 12 A
- **24 V Amperage***: Startup: 14 A; Running: 6 A
- **Operating Temperatures**: -40 °C to 80 °C
- **Motor Life****: 18 000-20 000 hours
- **Warranty**: 3 Years

The brushed motor does not come with enhanced EMI protection¹. The RESPA-CF2 with a compact motor is warranted for two (2) years from date of purchase.

The brushless motor includes over/under-voltage, overheating protection. The RESPA-CF2 with a brushless motor is warranted for three (3) years from date of purchase.

*Amperage numbers above are averages; actual motor am draw may vary.

**Excepted motor life based on standard operating conditions.

¹Conforms with EN13309:2010.

RESPA-CF2 Brushed Compact Motor Systems

Part Number	Voltage	Filter			Outer Diameter		Optional Filtration	
		Type	Part Number	Length	101.6 mm	76.2 mm	Odour/Hepa	Gas/Hepa
RCF2033	12	MERV 16/F9 ¹	FEFF108	STANDARD	•		•	
RCF2034	24							
RCF2041	12	HEPA/H13 ²	FEFF118					
RCF2042	24							
RCF2035	12	MERV 16/F9 ¹	FEFF109	EXTENDED	•		•	•
RCF2036	24							
RCF2043	12	HEPA/H13 ²	FEFF119					
RCF2044	24							
RCF2037	12	MERV 16/F9 ¹	FEFF108	STANDARD		•	•	
RCF2038	24							
RCF2045	12	HEPA/H13 ²	FEFF118					
RCF2046	24							
RCF2039	12	MERV 16/F9 ¹	FEFF109	EXTENDED		•	•	•
RCF2040	24							
RCF2047	12	HEPA/H13 ²	FEFF119					
RCF2048	24							

RadialSHIELD Filtration Options

- **Particulate Filters:**
 - MERV 16*/ F9
 - *Media rated at MERV 16
 - HEPA/H13²
- **Odour/Particulate Combination Filter:**
 - Odour + HEPA/H13
- **Gas/Particulate Combination Filters:**
 - Gas + HEPA/H13²



Filtration Standards and Ratings

- **MERV 16/F9:** Media rated MERV 16 at 150 CFM (255 m³/h) airflow with 95% efficiency of 0.3 µm to 1.0 µm particle size; Rated F9 under EN779 at 150 CFM (255 m³/h) airflow with 95% efficiency of 0.4 µm (Em) particle size.
- **HEPA/H13/ISO 35H:** Rated H13 under EN1822-1 and 35H under ISO 29463-1 at 100 CFM (170 m³/h) with initial efficiency 99.95% at MPPS (0.1 µm to 0.3 µm particle size).
- **Odor + HEPA/H13:** Qualified as Odour Retention under ISO 11155-2. Rated H13 under EN1822-1 and 35H under ISO 29463-1 at 50 CFM (85 m³/h) with initial efficiency 99.95% at MPPS (0.1 µm to 0.3 µm particle size).
- **Gas ABEK1 + HEPA/H13:** Rated ABEK1 under EN12941:1998 + A1:2004 + A2:2008. Rated H13 under EN1822-1 and 35H under ISO 29463-1 at 50 CFM (85 m³/h) with initial efficiency 99.95% at MPPS (0.1 µm to 0.3 µm particle size).

RESPA-CF2 Systems • 4-inch Outlet, Standard Length Filter, Brushless Motor

Part Number	Voltage	Filter			Outer Diameter	Weight	Dimensions		
		Type	Part Number	Length			Length	Width	Height
RCF2009	12	MERV 16/F9 ¹	FEFF108	STANDARD	101.6 mm	5.4 kg	601 mm	254 mm	286 mm
RCF2010	24								
RCF2025	12	HEPA/H13 ²	FEFF118						
RCF2026	24								

¹Media rated at MERV 16, F9 under EN779. ²Rated H13 under EN1822-1.
 Units include rain cap and base mount with clamp brackets.
 Optional flange mount available.
 Standard length precleaners require 6.25 inches (159 mm) for filter removal.

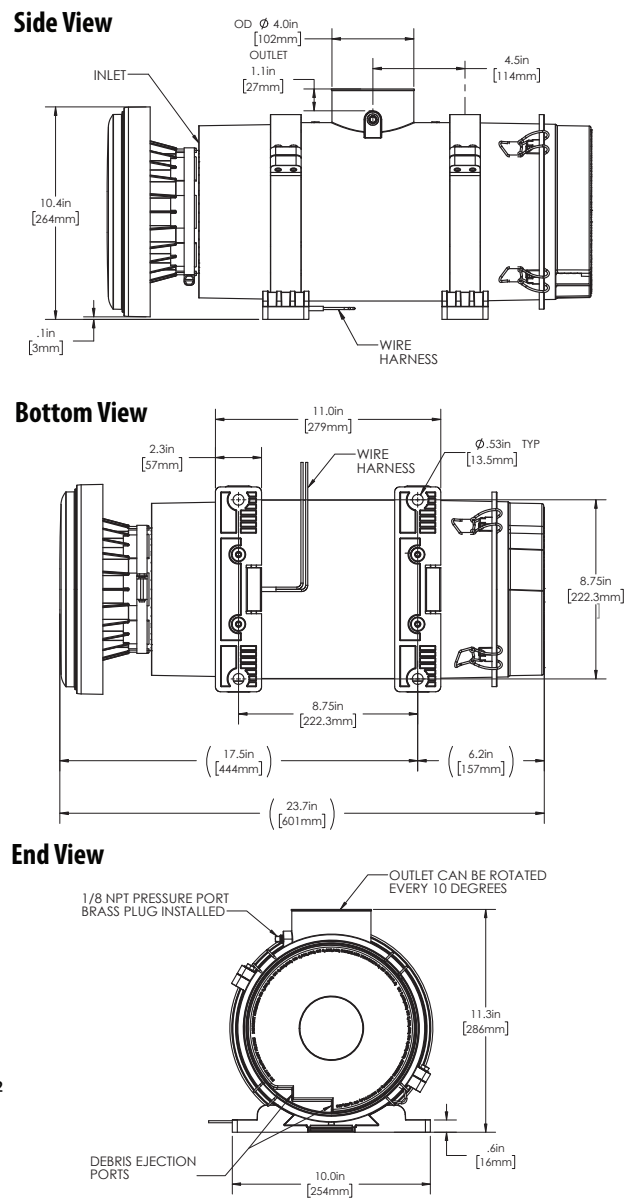
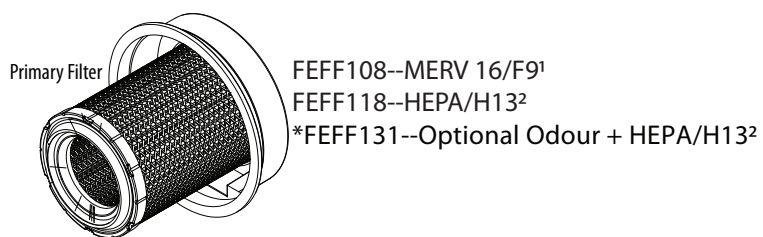
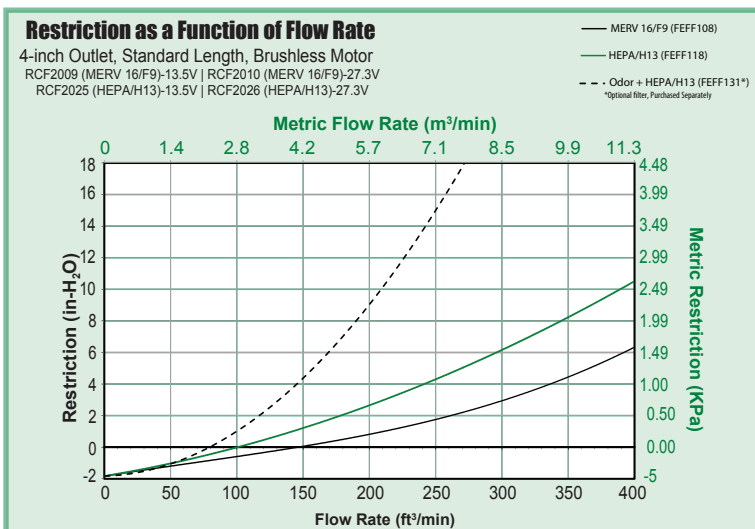

RESPA-CF2 Systems • 4-inch Outlet, Extended Length Filter, Brushless Motor

Part Number	Voltage	Filter			Outer Diameter	Weight	Dimensions		
		Type	Part Number	Length			Length	Width	Height
RCF2011	12	MERV 16/F9 ¹	FEFF109	EXTENDED	101.6 mm	6.6 kg	728 mm	254 mm	286 mm
RCF2012	24								
RCF2027	12	HEPA/H13 ²	FEFF119						
RCF2028	24								

¹Media rated at MERV 16, F9 under EN779. ²Rated H13 under EN1822-1.
 Units include rain cap and base mount with clamp brackets.
 Optional flange mount available.
 Standard length precleaners require 12.25 inches (311 mm) for filter removal.

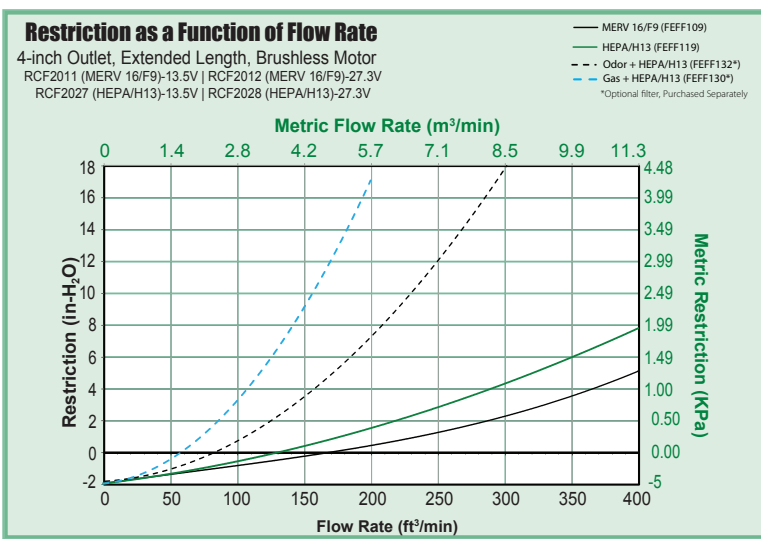

Side View

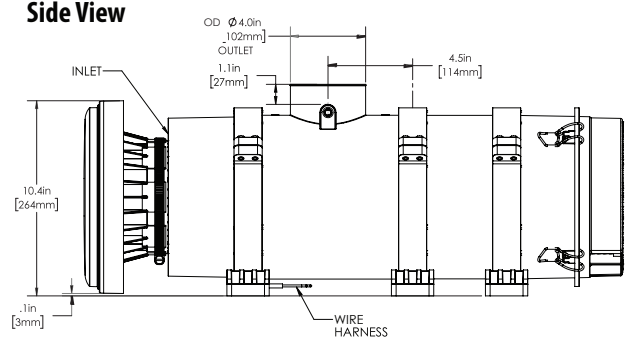

Bottom View

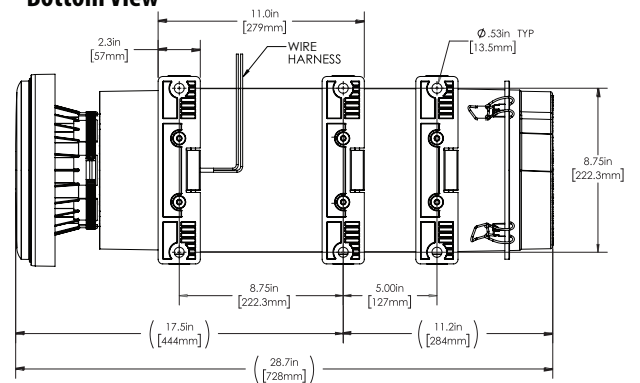

End View

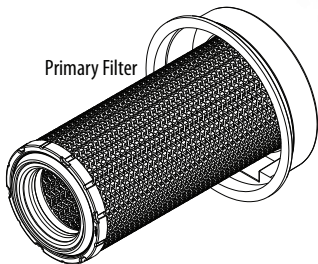
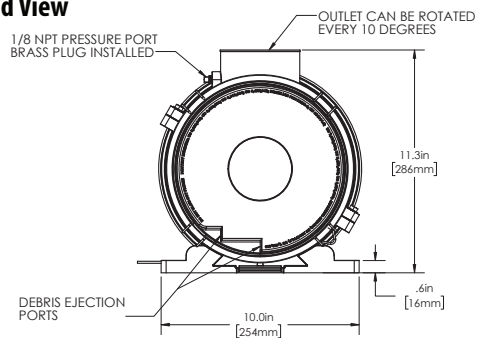

FEFF109--MERV 16/F9¹
 FEFF119--HEPA/H13²
 *FEFF132--Optional Odour + HEPA /H13²
 *FEFF130--Optional Gas + HEPA /H13²
 *Purchased Separately

RESPA-CF2 Systems • 3-inch Outlet, Standard Length Filter, Brushless Motor

Part Number	Voltage	Filter			Outer Diameter	Weight	Dimensions		
		Type	Part Number	Length			Length	Width	Height
RCF2013	12	MERV 16/F9 ¹	FEFF108	STANDARD	76.2 mm	5.3 kg	601 mm	254 mm	286 mm
RCF2014	24								
RCF2029	12	HEPA/H13 ²	FEFF118						
RCF2030	24								

¹Media rated at MERV 16, F9 under EN779. ²Rated H13 under EN1822-1.
 Units include rain cap and base mount with clamp brackets.
 Optional flange mount available.
 Standard length precleaners require 6.25 inches (159 mm) for filter removal.

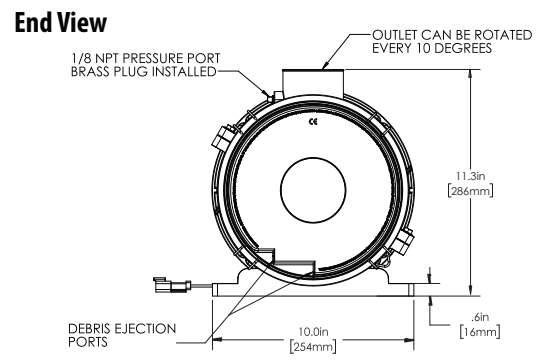
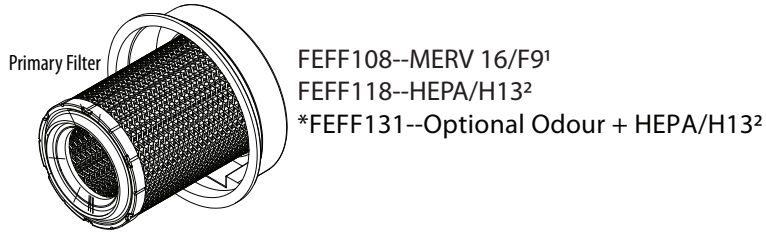
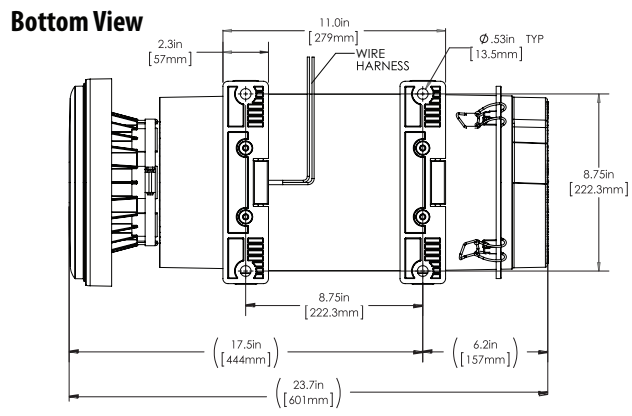
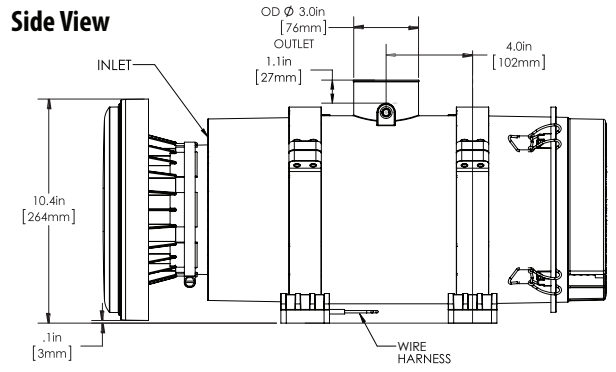
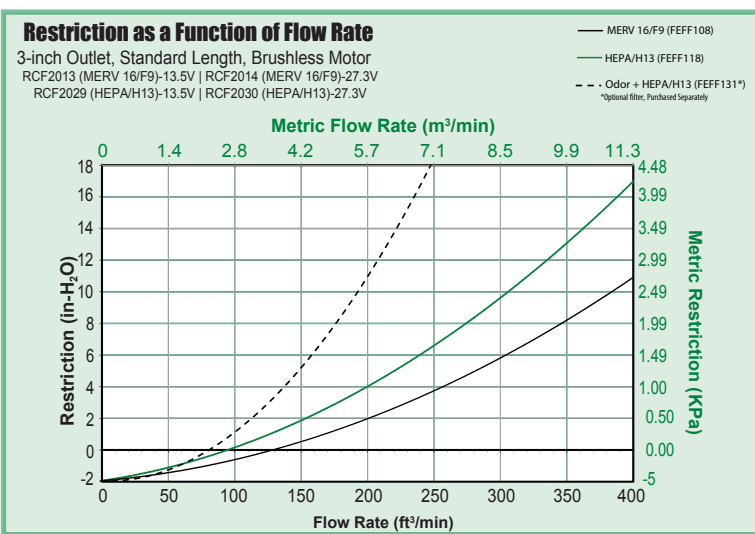

RESPA-CF2 Systems • 3-inch Outlet, Extended Length Filter, Brushless Motor

Part Number	Voltage	Filter			Outer Diameter	Weight	Dimensions		
		Type	Part Number	Length			Length	Width	Height
RCF2015	12	MERV 16/F9 ¹	FEFF109	EXTENDED	76.2 mm	6.4 kg	728 mm	254 mm	286 mm
RCF2016	24								
RCF2031	12	HEPA/H13 ²	FEFF119						
RCF2032	24								

¹Media rated at MERV 16, F9 under EN779. ²Rated H13 under EN1822-1.
 Units include rain cap and base mount with clamp brackets.
 Optional flange mount available.
 Standard length precleaners require 12.25 inches (311 mm) for filter removal.

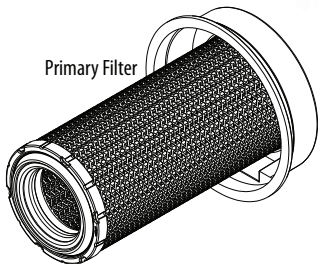
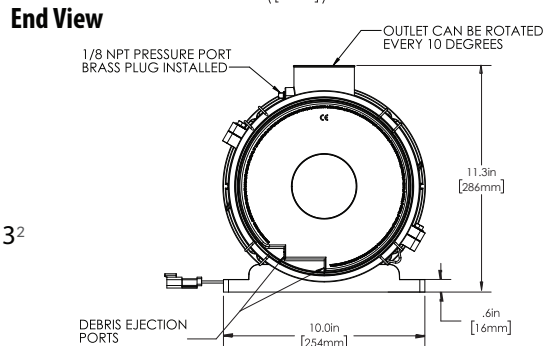
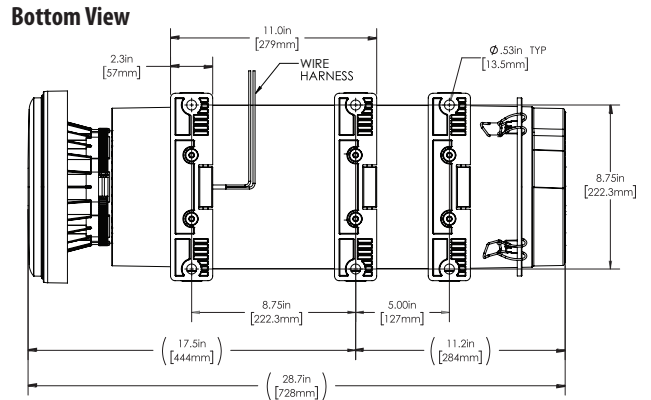
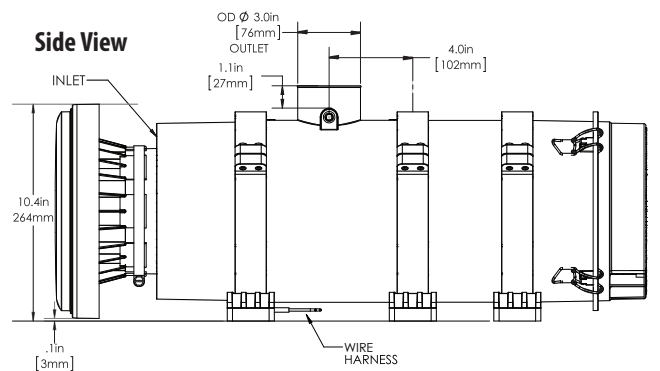
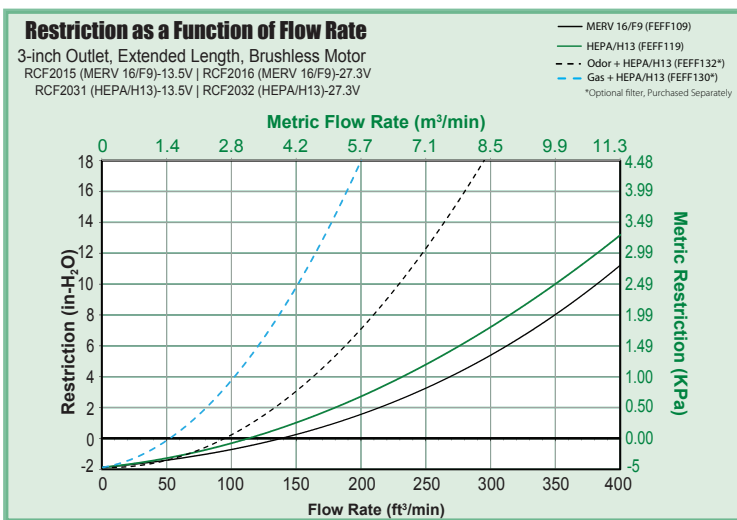

FEFF109--MERV 16/F9¹
 FEFF119--HEPA/H13²
 *FEFF132--Optional Odour + HEPA /H13²
 *FEFF130--Optional Gas + HEPA /H13²
 *Purchased Separately

RESPA-CF2 Systems • 4-inch Outlet, Standard Length Filter, Brushed Compact Motor

Part Number	Voltage	Filter			Outer Diameter	Weight	Dimensions		
		Type	Part Number	Length			Length	Width	Height
RCF2033	12	MERV 16/F9 ¹	FEFF108	STANDARD	102 mm	4.9 kg	505 mm	261 mm	286 mm
RCF2034	24								
RCF2041	12	HEPA/H13 ²	FEFF118						
RCF2042	24								

¹Media rated at MERV 16, F9 under EN779. ²Rated H13 under EN1822-1.
 Units include rain cap and base mount with clamp brackets.
 Optional flange mount available.
 Standard length precleaners require 6.25 inches (159 mm) for filter removal.

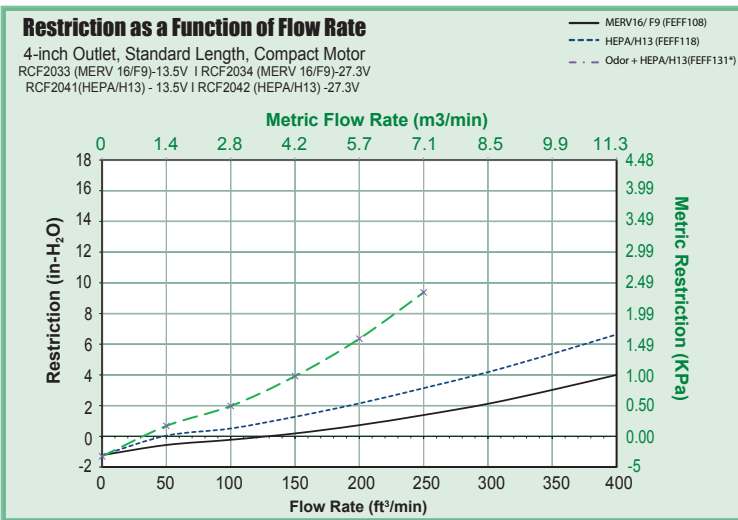

Side View

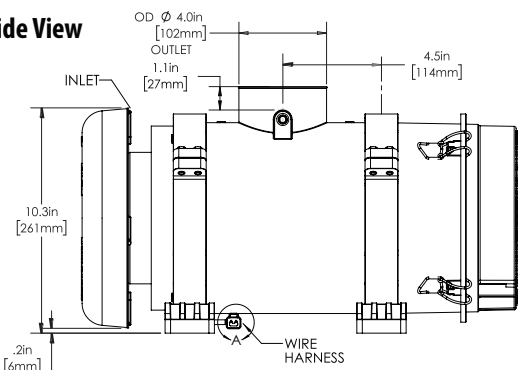

Bottom View

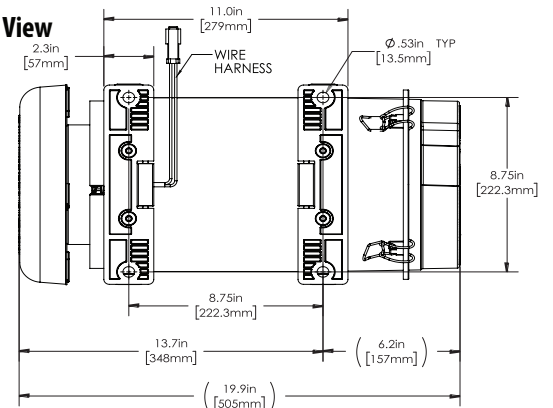

End View

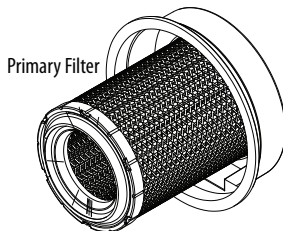
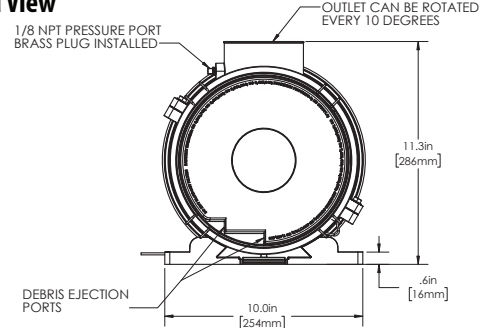

FEFF108--MERV 16/F9¹
 FEFF118--HEPA/H13²
 *FEFF131--Optional Odour + HEPA/H13²

RESPA-CF2 Systems • 4-inch Outlet, Extended Length Filter, Brushed Compact Motor

Part Number	Voltage	Filter			Outer Diameter	Weight	Dimensions		
		Type	Part Number	Length			Length	Width	Height
RCF2035	12	MERV 16/F9 ¹	FEFF109	EXTENDED	76.2 mm	6.0 kg	632 mm	254 mm	286 mm
RCF2036	24								
RCF2043	12	HEPA/H13 ²	FEFF119						
RCF2044	24								

¹Media rated at MERV 16, F9 under EN779. ²Rated H13 under EN1822-1.
 Units include rain cap and base mount with clamp brackets.
 Optional flange mount available.
 Standard length precleaners require 12.25 inches (311 mm) for filter removal.

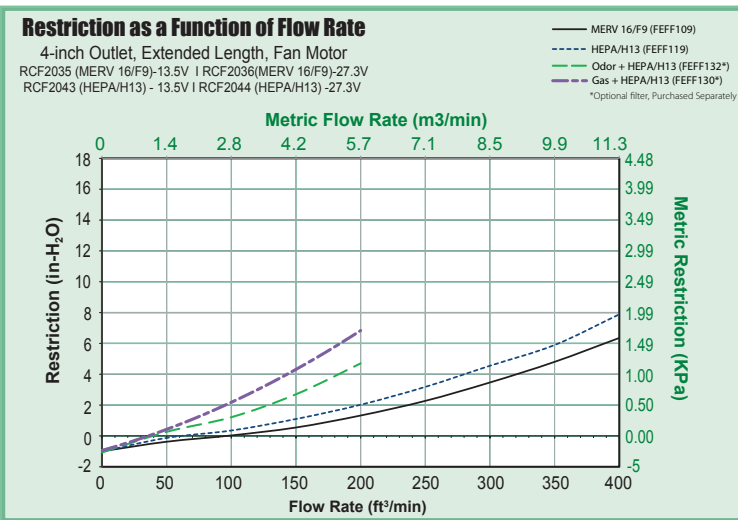

Side View

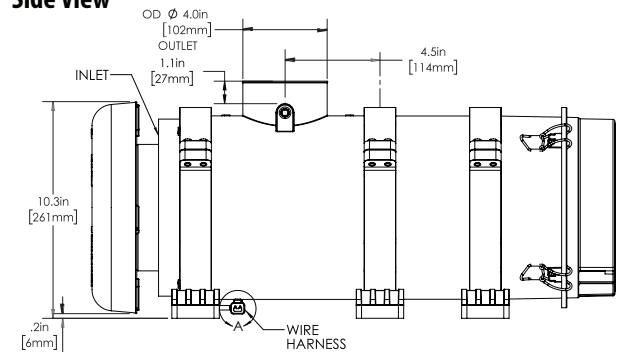

Bottom View

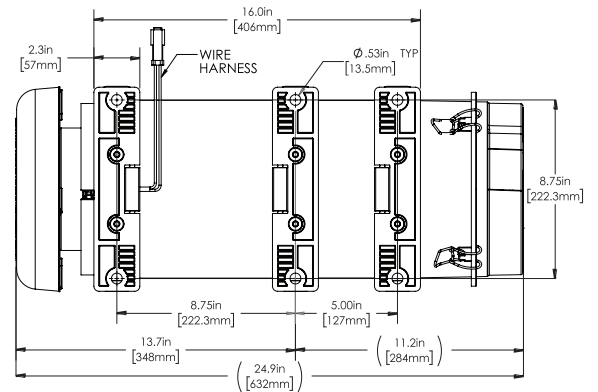

End View

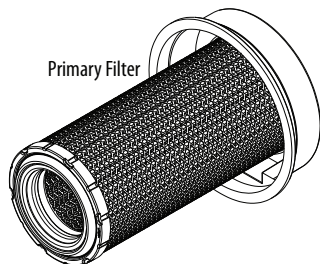
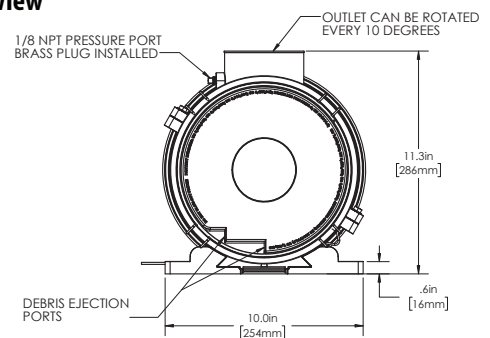

FEFF109--MERV 16/F9¹
 FEFF119--HEPA/H13²
 *FEFF132--Optional Odour + HEPA /H13²
 *FEFF130--Optional Gas + HEPA /H13²
 *Purchased Separately

RESPA-CF2 Systems • 3-inch Outlet, Standard Length Filter, Brushed Compact Motor

Part Number	Voltage	Filter			Outer Diameter	Weight	Dimensions		
		Type	Part Number	Length			Length	Width	Height
RCF2037	12	MERV 16/F9 ¹	FEFF108	STANDARD	76.2 mm	4.8 kg	479 mm	254 mm	286 mm
RCF2038	24								
RCF2045	12	HEPA/H13 ²	FEFF118						
RCF2046	24								

¹Media rated at MERV 16, F9 under EN779. ²Rated H13 under EN1822-1.
 Units include rain cap and base mount with clamp brackets.
 Optional flange mount available.
 Standard length precleaners require 6.25 inches (159 mm) for filter removal.

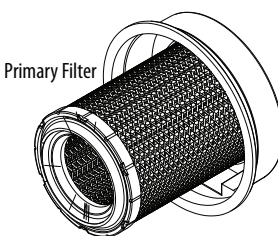
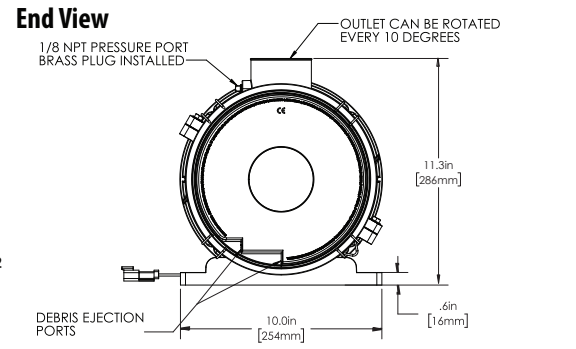
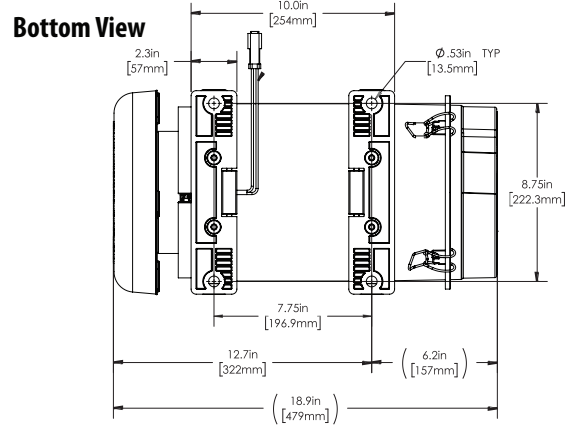
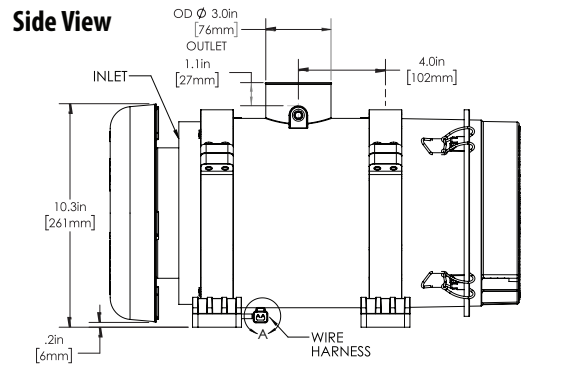
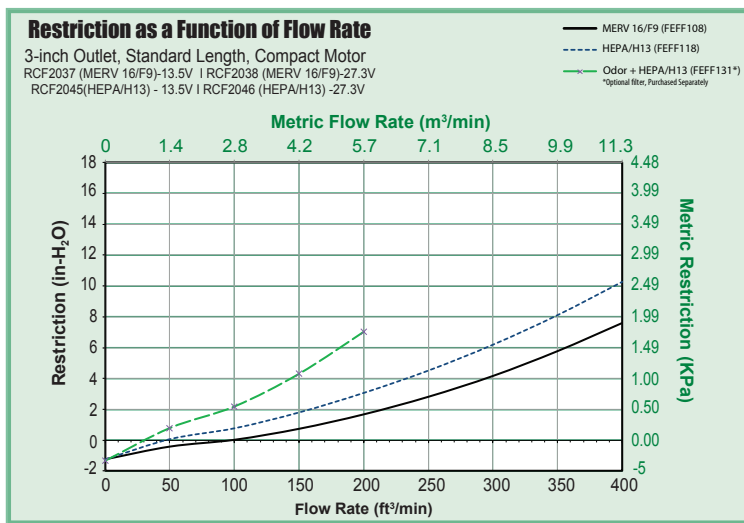

FEFF108--MERV 16/F9¹
 FEFF118--HEPA/H13²
 *FEFF131--Optional Odour + HEPA/H13²

RESPA-CF2 Systems • 3-inch Outlet, Extended Length Filter, Brushed Compact Motor

Part Number	Voltage	Filter			Outer Diameter	Weight	Dimensions		
		Type	Part Number	Length			Length	Width	Height
RCF2039	12	MERV 16/F9 ¹	FEFF109	EXTENDED	76.2 mm	5.9 kg	606 mm	254 mm	286 mm
RCF2040	24								
RCF2047	12	HEPA/H13 ²	FEFF119						
RCF2048	24								

¹Media rated at MERV 16, F9 under EN779. ²Rated H13 under EN1822-1.
Units include rain cap and base mount with clamp brackets.
Optional flange mount available.
Standard length precleaners require 12.25 inches (311 mm) for filter removal.

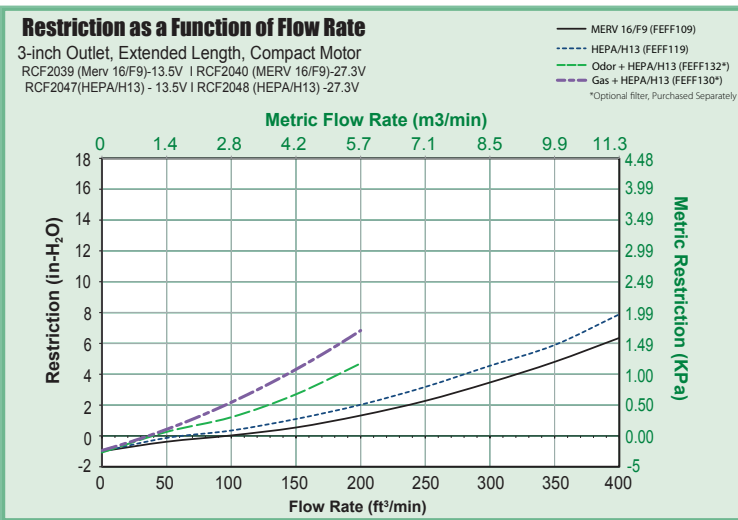

Side View

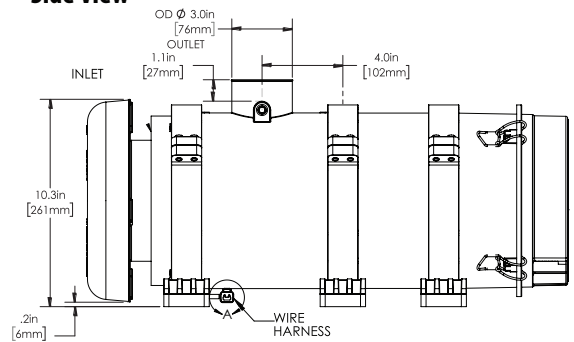

Bottom View

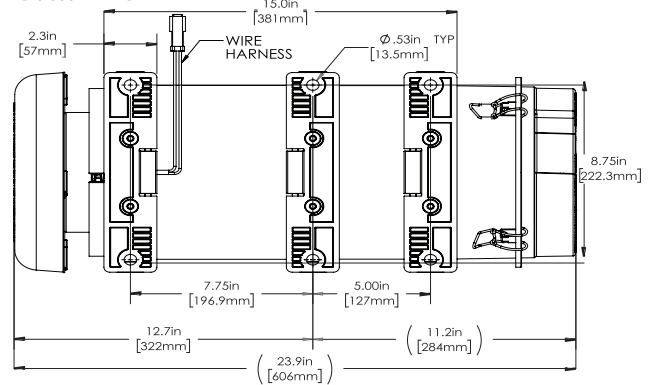

End View

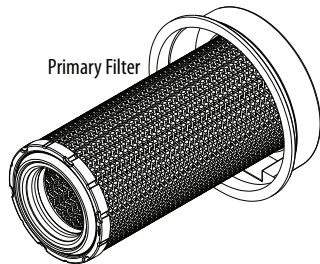
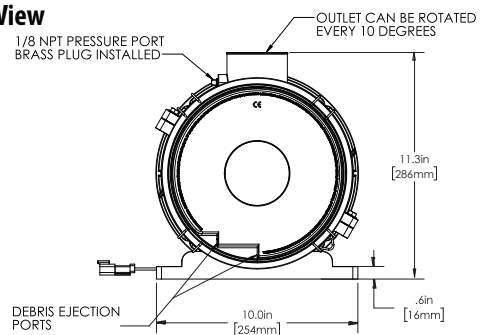

FEFF109--MERV 16/F9¹
 FEFF119--HEPA/H13²
 *FEFF132--Optional Odour + HEPA /H13²
 *FEFF130--Optional Gas + HEPA /H13²
 *Purchased Separately

RESPA-CF2 Adaptation Parts

RIC0701 Optional Flange Mount

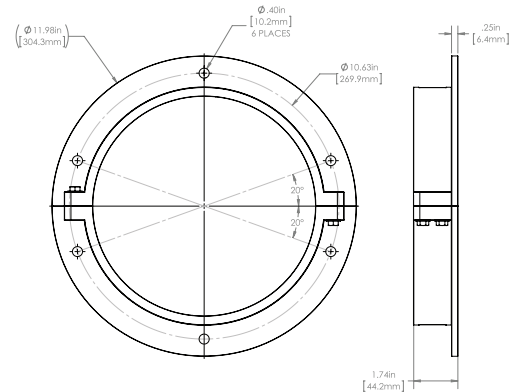
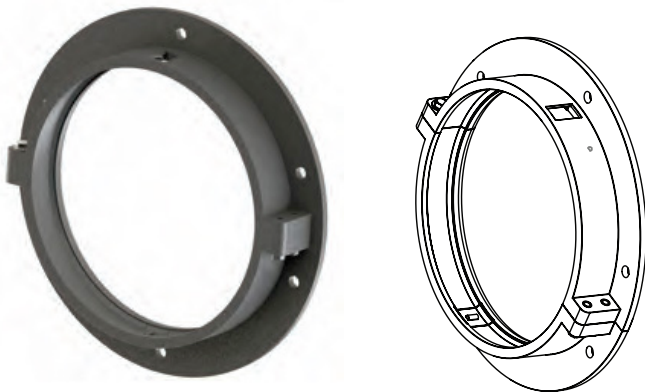

Mounting Examples:

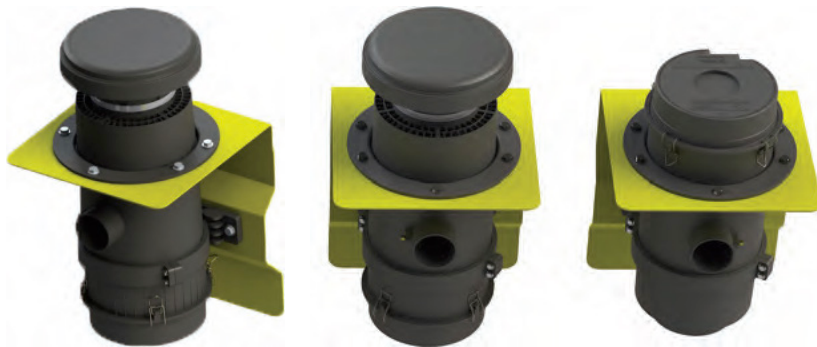

- The RESPA-CF2 can be mounted vertically or horizontally.
- Debris ejection port can be oriented in any direction, as long as it is away from the operator and painted surfaces.

RESPA-CF2 Installation Kits

Part Number	Service Part Description
GK015	RESPA-CF2 Installation Kit: 3-inch and 4-inch

RESPA-CF2 Service Parts

Part Number	Service Part Description
RCF2901	RESPA-CF2 Service Part: Rain Cap
RCF2903	RESPA-CF2 Service Part: 12-Volt Brushless Motor
RCF2905	RESPA-CF2 Service Part: 24-Volt Brushless Motor
RCF2908	RESPA-CF2 Service Part: Clamp Assembly
RCF2909	RESPA-CF2 Service Part: Filter Ring
RCF2910	RESPA-CF2 Service Part: Extended Filter Ring
RCF2911	RESPA-CF2 Service Part: Inlet Screen for Internal Motor
RCF2912	RESPA-CF2 Service Part: 3-inch Outlet Housing
RCF2913	RESPA-CF2 Service Part: 4-inch Outlet Housing
RCF2915	RESPA-CF2 Service Part: 12/24 Wiring Kit
RCF2918	RESPA-CF2 Service Part: 12-Volt Compact Brushed Motor Kit
RCF2919	RESPA-CF2 Service Part: 24-Volt Compact Brushed Motor Kit
RCF2920	RESPA-CF2/XLR Service Part: Compact Brushed Motor Rain Cap
AD0197	4-inch Flange Assembly Boxed
AD0198	3-inch Flange Assembly Boxed
REC0157	RESPA-CF/CF2 Mounting Plate



RESPA-CF2 Installation Kit for 3-inch and 4-inch

RESPA-CF2 Brushless Service Parts: Exploded Diagrams

Standard Length



Extended Length

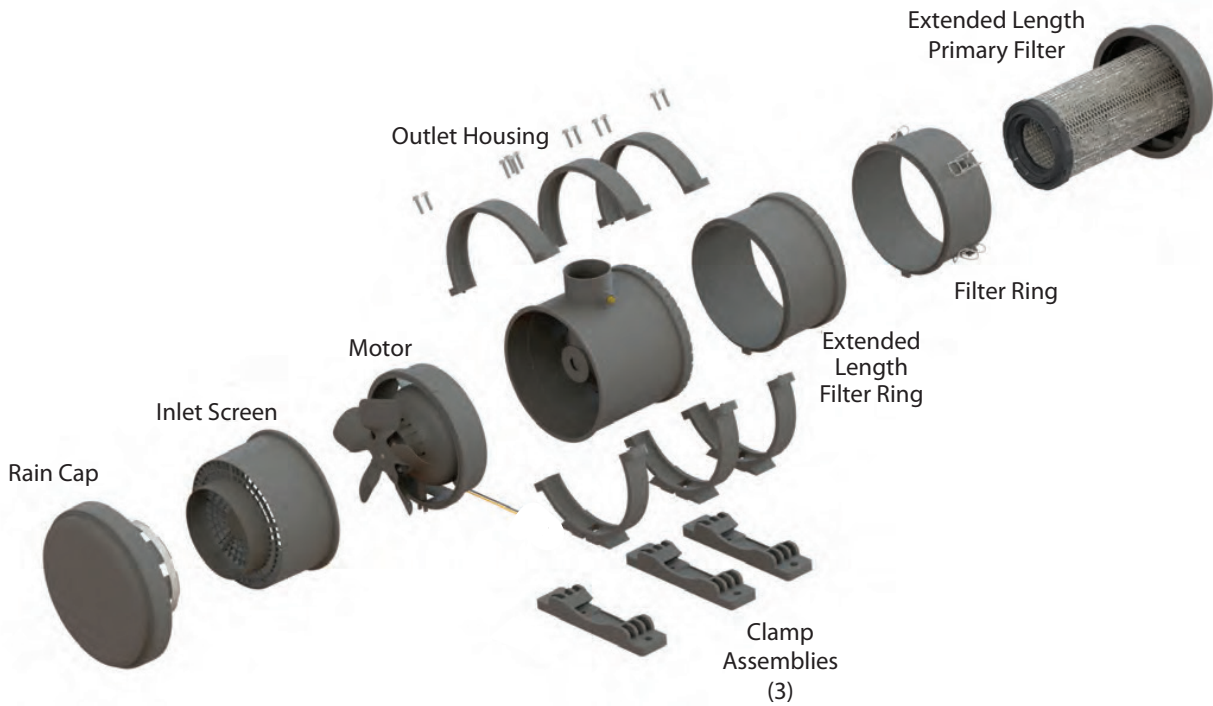

RESPA-CF2 Brushed Compact Motor Service Parts: Exploded Diagrams

Standard Length

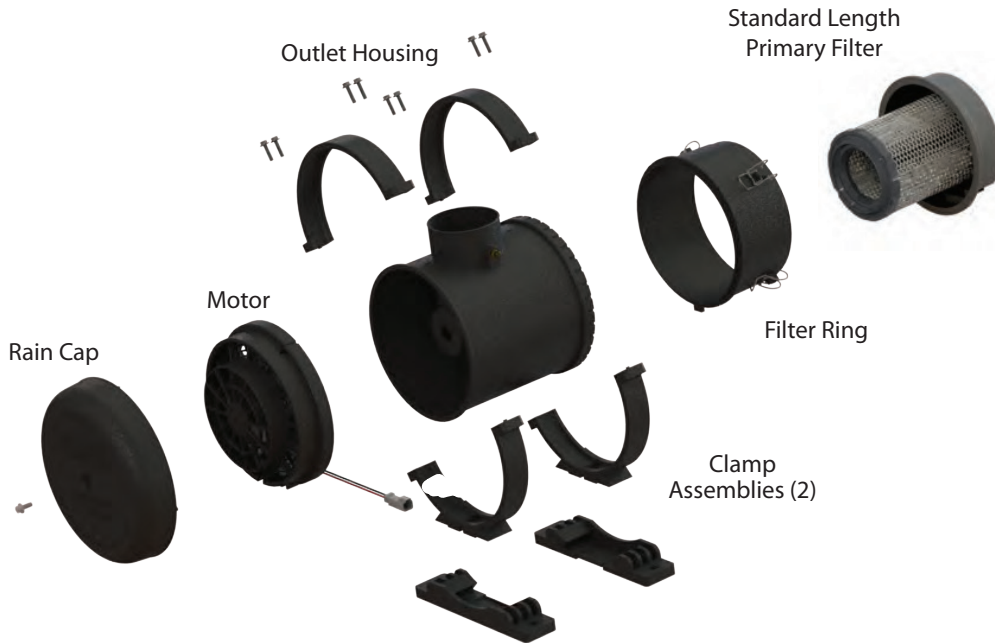

Extended Length

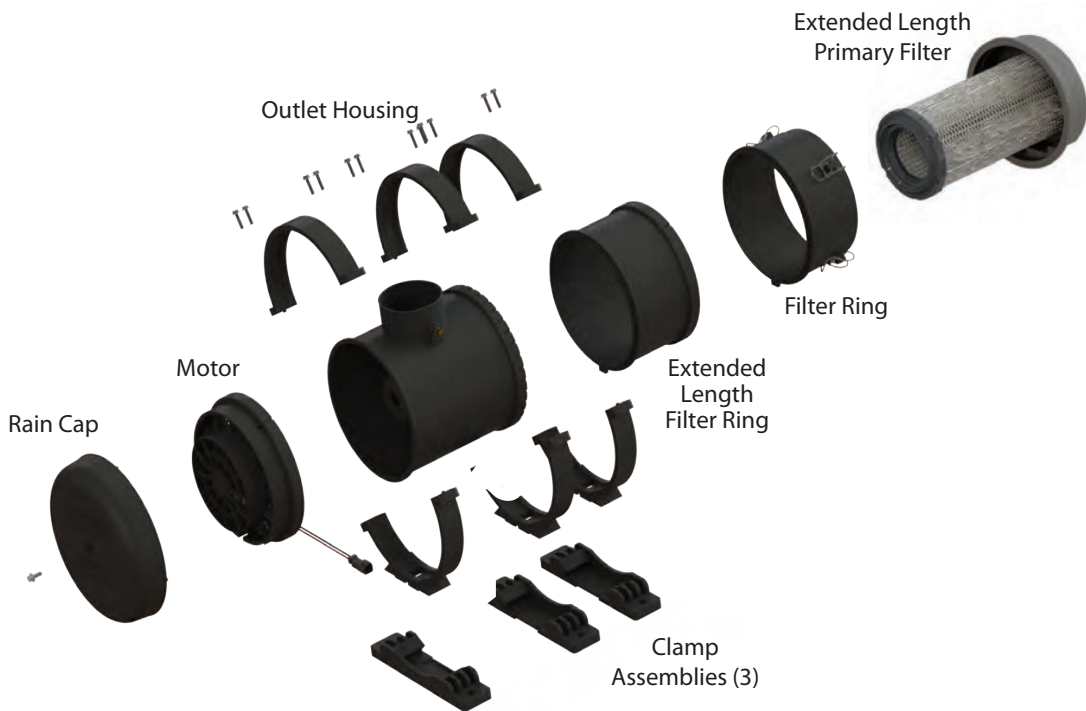

RESPA-CF2 Filter Change Instructions

1

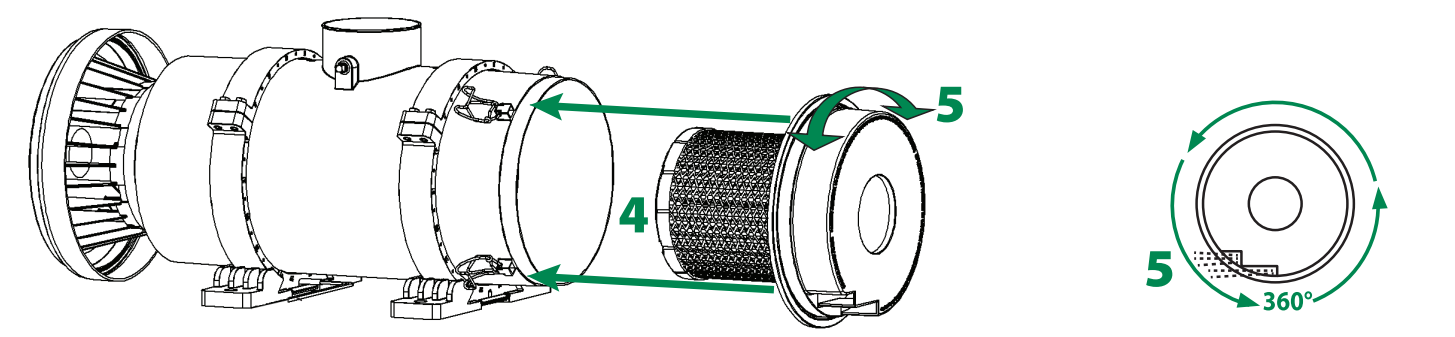
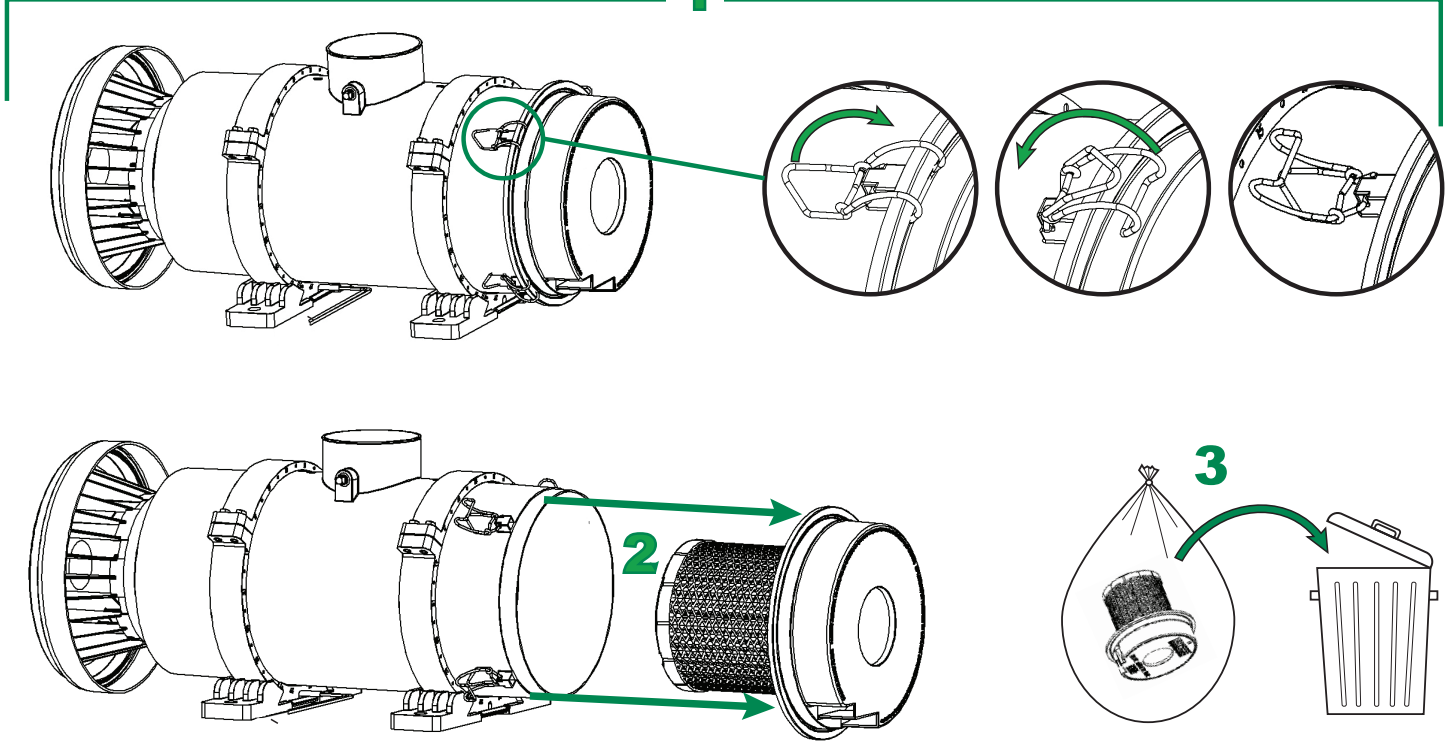

6

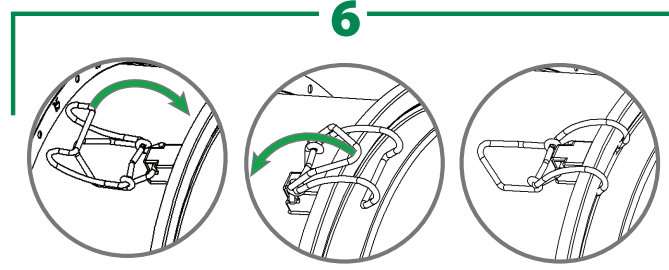

This product may not be a stock item. Please speak to our sales representative about lead times. Lead times, price, and availability can only be determined on receipt of an official quote from our supplier. This can sometimes take up to 3 days.

- | | | |
|--|---|---|
| Gauteng - Jet Park (HQ):
T: +27 (0)11 823 5650 | Mpumalanga - Middelburg:
T: +27 (0)13 692 8132 | Botswana, Gaborone:
T: +267 399 4150 |
| Free State - Bloemfontein:
T: +27 (0)63 257 0505 | Northern Cape - Kathu:
T: +27 (0)53 723 3415 | Botswana, Lethakane:
T: +267 297 8568 |
| Eastern Cape - Port Elizabeth:
T: +27 (0)82 450 6596 | North West - Rustenburg:
T: +27 (0)14 596 5257 | Mozambique, Tete:
T: +258 252 20666 |
| KwaZulu Natal - Pinetown:
T: +27 (0)31 303 4129 | Western Cape - Cape Town:
T: +27 (0)21 945 1453 | Zambia, Kitwe:
T: +26 (0)21 222 5338 |



Call us today!

TRYSOME
AUTO-ELECTRICAL ENGINEERING

Delivering Optimal **Uptime!**