

## SUITABLE FOR HARSH CONDITIONS



### Technical Data

<b>Theoretical Lumens Output:</b>	1 950 Lumens
<b>Operational Lumens Output:</b>	1 500 Lumens
<b>Colour Temperature:</b>	5 700 K
<b>Nominal Voltage DC:</b>	12 V, 24 V
<b>Input Voltage Range DC:</b>	9 - 16 V, 18 - 32 V
<b>Power Consumption:</b>	28 w
<b>Nominal Current at 24 V:</b>	12 V = 2.4 A, 24 V = 1.2 A
<b>Connector:</b>	Built-in Deutsch DT-2 (2-pin)
<b>Mount:</b>	Single Bolt M8
<b>Shock:</b>	60 G
<b>Vibration:</b>	8 Grms 24-2000 Hz
<b>Lens:</b>	Glass
<b>Body/Housing:</b>	Aluminium
<b>Weight:</b>	0.6 kg
<b>IP Rating:</b>	IP68, IP6K9K
<b>Salt Spray Test:</b>	ISO 9227 240H
<b>EMC:</b>	CISPR 25 Class 5, EN 14982-2, ISO 13766, EN 12895, ISO 11452-2, EN 13309, ISO 7637-2
<b>Operating Temperatures:</b>	-40° C... +85° C (Overheat protected)
<b>Electronics:</b>	Isolated

The **NORDIC LIGHTS® Scorpius PRO 415 Phenom Optics** is an extremely useful work light delivering a three-in-one optical solution through our Phenom Optics solution (patent pending). With this work light mounted on your heavy-duty vehicle, you will have accent lighting with soft illumination directed upwards as a guide light for lifting or other operations and efficient task lighting to illuminate the work area both directly in front of and further from the vehicle. Most importantly, people and other vehicles working nearby will not be blinded thanks to the glare-free zone it creates.

This LED work light is compact and lightweight, ideal for vehicles in material handling and construction. The **Scorpius PRO 415 PH** offers effective illumination with an operational lumen output of 1 500 lumens and excellent colour rendering in warm, natural hues. It has an asymmetrical wide flood light pattern and withstands vibrations of up to 8 Grms. Thanks to its glass lens and new strengthened aluminium housing, this work light has a high level of mechanical, thermal and corrosion resistance.

**Light Patterns**

Wide Flood - T989-101B  
 Scorpius PRO 415 PH, 1 500 Lumens

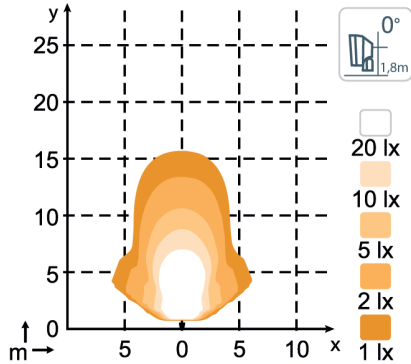

**Connector**

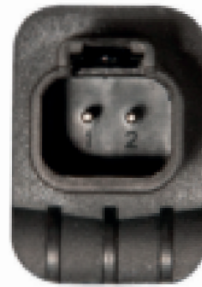

Built-in Deutsch DT-2 (2-pin)

**Key Features**

- Glare-free, will not blind people near the vehicle (PATENT PENDING WO2019073105)
- Maximum safety and high visibility with light focused on the desired areas
- Superior electromagnetic compatibility
- CISPR 25 Class 5

**Dimensions**

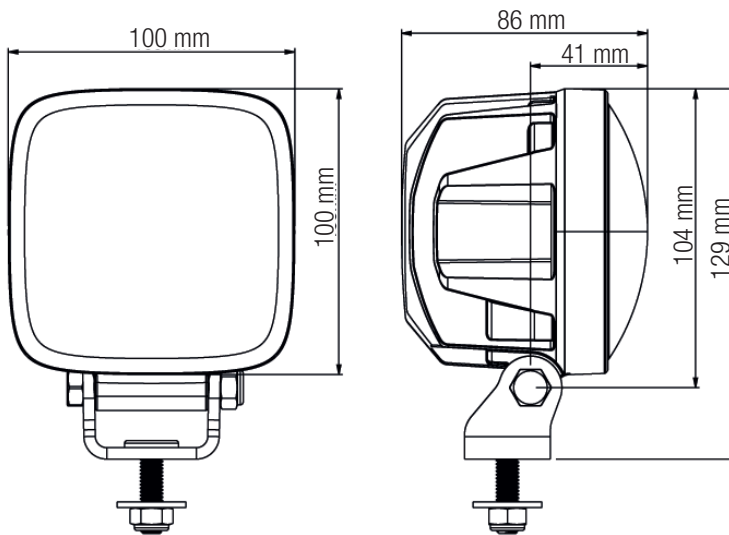

This may not be a stock item. Please speak to our sales representative about lead times. Lead times, price and availability can only be determined on receipt of an official quote from our supplier. This can sometimes take up to 3 days.

<b>Gauteng (HO):</b> T: +27 (0)11 823 5650	<b>North West:</b> T: +27 (0)14 596 5257	<b>Eastern Cape:</b> T: +27 (0)81 036 9111	<b>Botswana, Letlhakane:</b> T: +267 297 8568
<b>KwaZulu Natal:</b> T: +27 (0)31 303 4129	<b>Mpumalanga:</b> T: +27 (0)13 692 8132	<b>Free State:</b> T: +27 (0)63 257 0505	<b>Mozambique:</b> T: +258 252 20666
<b>Northern Cape:</b> T: +27 (0)53 723 3415	<b>Western Cape:</b> T: +27 (0)21 945 1453	<b>Botswana, Jwaneng:</b> T: +267 588 7617	<b>Zambia:</b> T: +26 (0)21 222 5338